



PBPB15EL

Electric Pallet Truck 1.5 Ton

PBPB15EL

Electric Pallet Truck 1.5 Ton

Distinguishing mark				
1.1	Manufacturer			MLift
1.2	Model designation			PBPB15EL
1.3	Drive unit			Battery
1.4	Operator type			Pedestrian
1.5	Rated capacity	Q	kg	1500
1.6	Load center distance	c	mm	600
1.7	Load distance	x	mm	950(880)
1.8	Wheelbase	y	mm	1190(1120)
Weight				
2.1	Service weight (include battery)		kg	120
2.2	Axle loading, laden driving side/loading side		kg	480/1140
2.3	Axle loading, unladen driving side/loading side		kg	90/30
Types, Chassis				
3.1	Tyre type driving wheels/loading wheels			PU/PU
3.2	Tyre size, driving wheels (diameter×width)		mm	Φ210x70
3.3	Tyre size, loading wheels (diameter×width)		mm	Φ80x60(Φ74x88)
3.4	Tyre size, caster wheels (diameter×width)		mm	/
3.5	Wheels, number driving, caster/loading (x=drive wheels)		mm	1x, 4(1x, 2)
3.6	Track width, front, driving side	b10	mm	/
3.7	Track width, rear, loading side	b11	mm	410/(535)
Dimensions				
4.1	Lift height	h3	mm	115
4.2	Height drawbar in driving position min./max.	h14	mm	750/1190
4.3	Lowered height	h13	mm	80
4.4	Overall length	l1	mm	1540
4.5	Length to face of forks	l2	mm	400
4.6	Overall width	b1	mm	560(685)
4.7	Fork dimensions	s/ e/ l	mm	50x150x1150
4.8	Distance between fork-arms	b5	mm	560(685)
4.9	Ground clearance, center of wheelbase	m2	mm	30
4.10	Aisle width for pallets 1000 × 1200 crossways	Ast	mm	2145
4.11	Aisle width for pallets 800 × 1200 lengthways	Ast	mm	2050
4.12	Turning radius	Wa	mm	1330
Performance data				
5.1	Travel speed, laden/ unladen	km/ h	km/h	4.5/5
5.2	Lifting speed, laden/ unladen		m/ s	0.017/0.020
5.3	Lowering speed, laden/ unladen		m/ s	0.09/0.06
5.4	Max. gradeability, laden/unladen		%	6\16
5.5	Service brake type			electric
Electric-engine				
6.1	Drive motor rating S2 60 min		kW	0.75
6.2	Lift motor rating at S3 15%		kW	0.7
6.3	The maximum allowed size battery		mm	200x100x350
6.4	Battery voltage/nominal capacity K5		V/Ah	24/20
6.5	Battery weight		kg	7
Addition data				
7.1	Type of drive control			DC
7.2	Steering type			mechanical
7.3	Sound pressure level at the driver's ear		dB (A)	<74

If there are improvements of technical parameters or configurations, no further notice will be given.
The diagram shown may contain non-standard configurations.

Transport with Confidence Sophisticated, Powerful Electric Pallet Trucks

MLift Electric Pallet Trucks provide excellent turnaround performance across numerous applications.

With its compact turning radius and excellent steering control, the series is capable of navigating tight spaces easily.

With a powerful motor, this truck is capable of reaching 4.5km/h laden top speeds, making it ideal for long-distance trips without hitches. The electric pallet truck is integrated with Li-ion Battery and offers the benefits of Li-ion Battery.



✓ Enduring Operations

- Powerful drive control provides **enhanced load bearing capabilities**
- Heavy-lifting loads can be lifted with ease thanks to **powerful motors**
- **Functional design** with compact chassis structure allows operators to maneuver the pallet truck in tight spaces

✓ Heavy-duty Batteries

- **24V/20Ah Lithium-ion batteries** provide maximum performance in challenging terrains and longer operating hours
- **Lithium-ion batteries** with plug and play design for longer operating hours
- **Built-in safety standards** allowing operators to confidently operate at laden travel speeds reaching 4.5km/h

✓ Enhanced Load Stability

- **Low-profile frame** keeps objects out of the way and prevents injuries to the feet
- **Easy steering, easy maneuverability** thanks to the wide control handle
- **Low rolling resistance guaranteed** by well-designed steer and load wheels

✓ Robust Maintenance Features

- **Stringent market-testing** of components enhances operational safety and reliability
- **Long operating lifespan** is designed into the sturdy, single-piece casting of the pallet truck
- **Torsion-resistant chassis** enables safe loading of up to 1.5 tons



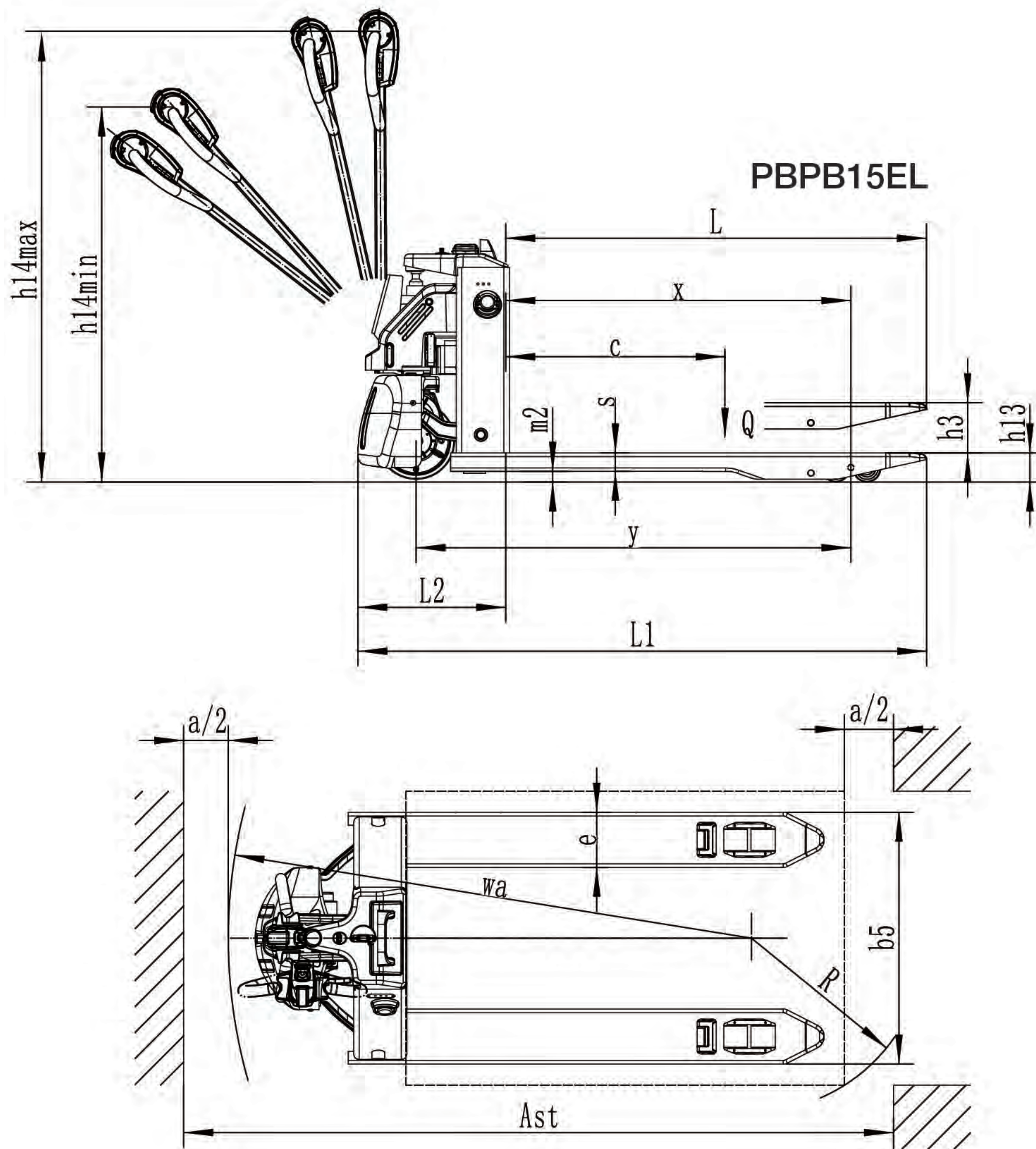

Option

Optional items	PBPB15EL
1 Fork length	900/1000/1220/1350/1500
2 Fork width	560/685
3 Double load wheel	●
4 Single load wheel	○
5 Driving wheel	-
6 Balance wheel	-
7 Cold storage	-
8 Battery indicator with hour meter	-
9 Battery indicator without hour meter	-
10 Battery capacity	24V/20Ah
11 Lateral change battery	-
12 Water auto-filling system	-
13 Vertical handler working	●
14 Half speed function in turning	-
15 Guard arm	-
16 Fork lowered height	-
17 Special backrest	-

Note: ● Standard ○ Matching - No